

Log Lighter Bar Kit



- ☑ Special adapter available for use with Propane
- ☑ Log lighter bar made of heavy duty cast iron
- ☑ Ledged design to eliminate falling ashes from blocking the orifices
- ☑ Log Lighter valve made of red brass with Teflon seat washer
- ☑ Available in straight and angle pattern
- ☑ CSA certified
- ☑ IAPMO listed

**AVAILABLE FOR
NATURAL GAS
AND PROPANE**



Propane Adapter

Log Lighter Bar has three ½" I.P.S. inlets to fit most applications. Two of the inlets are supplied with countersunk plugs. You can use ½" malleable street 90 fittings on each end of the bar to make standing legs.

Log Lighter Valves come in straight or angle pattern with a chrome plated flange and a 2-1/4" loose key.

- Valves are rated at 154,000 BTU/Hour rating at 1.0" water column.

Propane Adapter is required for use with propane gas.

Log Lighter Bar Kit

from Champion-Arrowhead

Available In
Natural Gas and
Propane Versions!

Straight Pattern Kit 258 Series

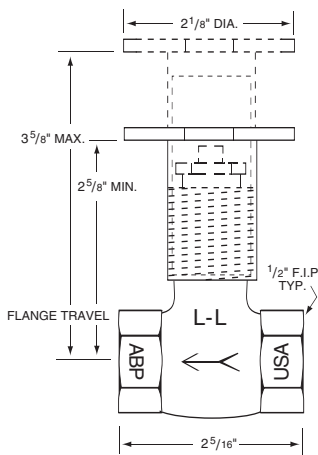

Straight Valve Diagram

Angle Pattern Kit 259 Series

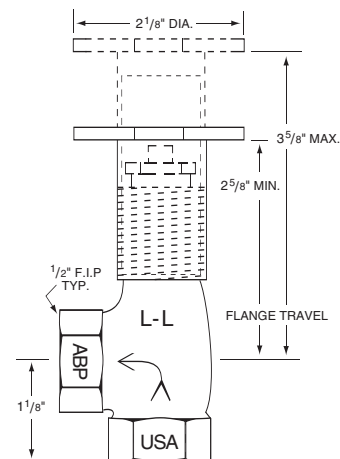

Angle Valve Diagram

Natural Gas		Propane Gas	
Part #	Description	Part #	Description
258K	Straight Pattern Kit	258KLP	Straight Pattern Kit
258	Straight Pattern Valve with Chrome Flange and Key -- No Bar	258LP	Straight Pattern Valve with Chrome Flange and Key — No Bar
259K	Angle Pattern Kit	259KLP	Angle Pattern Kit
259	Angle Pattern Valve with Chrome Flange and Key — No Bar	259LP	Angle Pattern Valve with Chrome Flange and Key -- No Bar



Champion-Arrowhead, LLC

5147 Alhambra Ave., Los Angeles, CA 90032

Phone : 323.221.9137. Fax : 323.221.2579

www.championarrowhead.com